



Installation Instructions

Part No: 00EFN900002700A, 00EFN900002800A, 00EFN900002900A

SAFETY CONSIDERATIONS

Installing, starting up, and servicing air-conditioning equipment can be hazardous due to system pressures, electrical components, and equipment location.

Only trained, qualified installers and service technicians should install, start up, and service this equipment.

When working on air-conditioning equipment, observe precautions in the literature and on tags, stickers, and labels attached to the equipment.

Follow all safety codes. Wear safety glasses and work gloves. Use care in handling equipment.

▲ WARNING

Be sure power to equipment is shut off before performing maintenance or service to avoid electrocution. Lock out and safety-tag all disconnects. There may be more than one disconnect.

GENERAL

This control accessory reduces 30XA chiller capacities below the standard lowest capacity step. This capacity reduction provides more precise control of leaving fluid temperature during light load conditions.

The minimum load control solenoid valve limits the amount of gas that can be bypassed from the condenser without impacting oil return.

One accessory package is required for 30XA080-350 units. Two accessory packages are required for 30XA400-500 units to accommodate connections for three refrigerant circuits. See Table 1 for accessory package usage.

Table 1 — Accessory Package Usage

30XA UNIT SIZE	ACCESSORY PART NO.
080-240	00EFN9000002700A
260-300	00EFN9000002800A
325, 350	00EFN9000002900A
400	00EFN9000002700A, 00EFN9000002800A
450, 500	00EFN9000002800A, 00EFN9000002900A

INSTALLATION

Examine the package contents for correct part numbers. If any of the components are damaged, file a claim with the shipping company and notify your Carrier representative.

See Table 2A, 2B, or 2C for package contents. See Fig. 1 for dimensional drawings of tubes included in the kit.

The following material is field supplied:

- 5/8 in. OD copper tubing
- 5/8 in. OD copper tube elbows and couplings (as required)
- Loctite 554 thread sealing compound
- Parker Super O-lube O-ring lubricant

Install the Solenoid Valve Tube Assembly

1. Remove refrigerant charge from the circuits using an approved refrigerant recovery device before proceeding with this installation. Follow good piping practices.
2. Locate the discharge manifold for minimum load piping on the side of the coil V for each circuit as shown in Fig. 2. Locate the 1/2 in. NPT pipe plugs on the top of the cooler for each circuit. See Fig. 3.
3. Remove the 1/2 in. NPT pipe plugs from the top of the cooler. Use the thread sealing compound and install one 1 in.-14 O-ring seal (ORS) x 1/2 in. NPT adapter for each circuit. Lightly lubricate each O-ring with O-lube and attach the tube assembly to each adapter. See Fig. 3. Be sure to attach the correct tube assembly to the cooler. Refer to the usage column in Tables 2A, 2B, and 2C for tube assembly part number corresponding to the unit size and circuit. The nut on the tube assembly should be torqued to 30 ft-lb (40 N-m).
4. Remove the trim panel on the discharge manifold for minimum load piping on the side of the coil V. Use a tubing cutter to cut 1 1/2 in. out from the discharge manifold for each circuit. See Fig. 4. Braze a tee in between the gap and, depending on the routing of the hot gas bypass tubing, have the tee's remaining port facing either left or right.
5. Use field-supplied 5/8 in. OD copper tubing and fittings (as required) to pipe from the solenoid valve outlet to the 5/8 in. port of the tee on the discharge manifold. Use the provided 5/8 in. tubing clamps to secure the tubing to the unit frame as necessary.
6. When piping is completed, leak test the assembly.
7. Evacuate, dehydrate, and recharge each circuit. Be sure to use the correct type and amount of refrigerant listed in the nameplate data and base unit documentation.
8. Restore power to the unit.

Table 2A — Contents of Accessory Kit, Part No. 00EFN900002700A

PART NUMBER	QUANTITY	DESCRIPTION	USAGE
00PSN500171700A	2	Tube assembly including solenoid valve, ball valve, and 90 degree bend tube assembly	One per circuit (circuit A and B for 30XA400). Cooler shell minimum load port, connect to 30GX5034892 adapter.
30GX5034892	2	1 in. -14 ORS x 1/2 in. NPT adapter	One per circuit. Cooler shell minimum load port.
00PPG000011600A	2	Solenoid coil assembly	One per circuit. Plug onto solenoid valve stub on 00PSN500171700A tube assembly.
KA66AA062	4	5/8 in. tube clamp	Secure minimum load piping to the frame as required.
DE40BA705	2	1 1/8 in. x 1 1/8 in. x 5/8 in. Tee	One per circuit. Discharge manifold on the side of condenser coil V.
TH70400410	2	Cable assembly	One per circuit. Connect to solenoid coil assembly and terminal block TB5 in control box.
00PPN500000401A	4	No. 10 Screw	Mount tube clamps
32GB500432E	1	HGBP/Pump board	Mount in control box
TH70400864	1	Harness assembly	Wiring between TB5 and HGBP/Pump board
HH83ZB001	1	24 v circuit breaker (CB14)	Mount on display bracket in control box
A6X10004352	4	No. 8 screw	Mount HGBP/Pump board
A6X10004434	4	Board mounting standoff	Mount HGBP/Pump board (30XA140-240,400: all voltages and 30XA080-120: 200/230 v, 380 v)
TH70400852	1	Communication cable assembly	30XA140-240,400: all voltages and 30XA080-120: 200/230 v, 380 v
HY89TB010	3	Wire nut	Splice communication cable (30XA080-120: 460 v, 575 v)

LEGEND

HGBP — Hot Gas Bypass
 ORS — O-Ring Seal
 TB — Terminal Block

Table 2B — Contents of Accessory Kit, Part No. 00EFN900002800A

PART NUMBER	QUANTITY	DESCRIPTION	USAGE
00PSN500171700A	2	Tube assembly including solenoid valve, ball valve, and 90 degree bend tube assembly	One per circuit (circuit A and B for 30XA400). Cooler shell minimum load port, connect to 30GX5034892 adapter.
30GX5034892	2	1 in. -14 ORS x 1/2 in. NPT adapter	One per circuit. Cooler shell minimum load port.
00PPG000011600A	2	Solenoid coil assembly	One per circuit. Plug onto solenoid valve stub on 00PSN500171700A tube assembly.
KA66AA062	4	5/8 in. tube clamp	Secure minimum load piping to the frame as required.
DE40BA705	2	1 1/8 in. x 1 1/8 in. x 5/8 in. Tee	One per circuit. Discharge manifold on the side of condenser coil V.
TH70400410	2	Cable assembly	One per circuit. Connect to solenoid coil assembly and terminal block TB5 in control box.
00PPN500000401A	4	No. 10 Screw	Mount tube clamps
32GB500432E	1	HGBP/Pump board	Mount in control box
TH70400864	1	Harness assembly	Wiring between TB5 and HGBP/Pump board
HH83ZB001	1	24 v circuit breaker (CB14)	Mount on display bracket in control box
A6X10004352	4	No. 8 screw	Mount HGBP/Pump board
A6X10004434	4	Board mounting standoff	Mount HGBP/Pump board (30XA260-300,400,450, 500: all voltages)
TH70400852	1	Communication cable assembly	30XA260-300,400,450,500: all voltages
HY89TB010	3	Wire nut	Splice communication cable

LEGEND

HGBP — Hot Gas Bypass
 ORS — O-Ring Seal
 TB — Terminal Block

Table 2C — Contents of Accessory Kit, Part No. 00EFN90002900A

PART NUMBER	QUANTITY	DESCRIPTION	USAGE
00PSN500175200A	2	Tube assembly including solenoid valve, ball valve, and 90 degree bend tube assembly	One per circuit (Circuit A and B for 30XA325, 350, circuit A and C for 30XA450, 500). Cooler shell minimum load port, connect to 30GX5034892 adapter.
30GX5034892	2	1 in. - 14 ORS x 1/2 in. NPT adapter	One per circuit. Cooler shell minimum load port.
00PPG000011600A	2	Solenoid coil assembly	One per circuit. Plug onto solenoid valve stub on 00PSN500171700A tube assembly.
KA66AA062	4	5/8 in. tube clamp	Secure minimum load piping to the frame as required.
DE40BA705	2	1 1/8 in. x 1 1/8 in. x 5/8 in. Tee	One per circuit. Discharge manifold on the side of condenser coil V.
TH70400410	2	Cable assembly	One per circuit. Connect to solenoid coil assembly and terminal block TB5 in control box.
00PPN50000401A	4	No. 10 screw	Mount tube clamps
32GB500432E	1	HGBP/Pump board	Mount in control box
TH70400864	1	Harness assembly	Wiring between TB5 and HGBP/Pump board
HH83ZB001	1	24V circuit breaker (CB14)	Mount on display bracket in control box
A6X10004352	4	No. 8 screw	Mount HGBP/Pump board
A6X10004434	4	Board mounting standoff	Mount HGBP/Pump board (325,350,450,500: all voltages)
TH70400852	1	Communication cable assembly	30XA325,350,450,500: all voltages.
HY89TB010	3	Wire nut	Splice communication cable

LEGEND

- HGBP — Hot Gas Bypass
- ORS — O-Ring Seal
- TB — Terminal Block

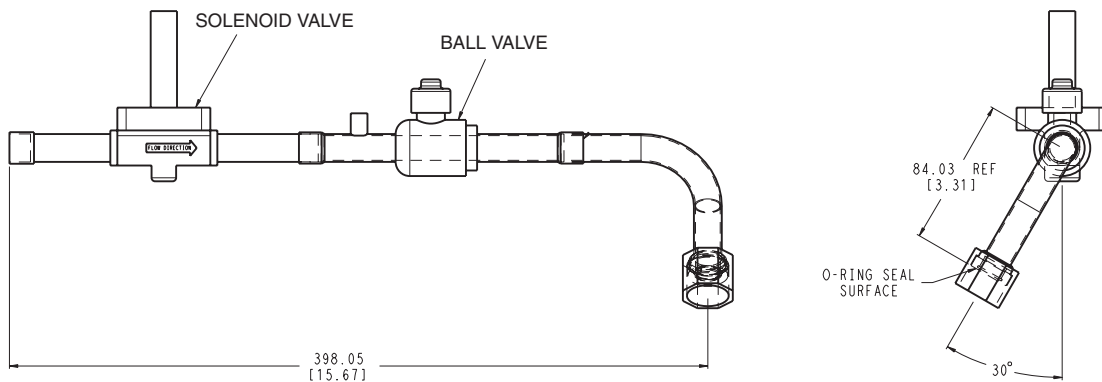

TUBE ASSEMBLY 00PSN500175200A

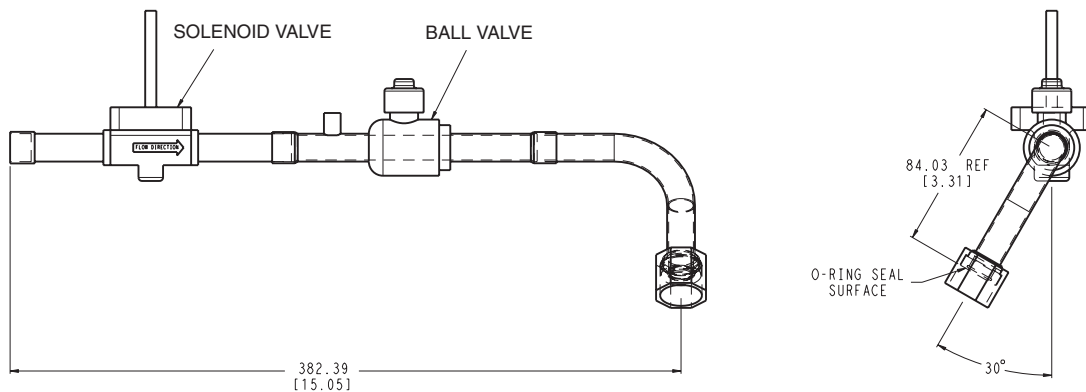

TUBE ASSEMBLY 00PSN500171700AA

NOTE: Dimensions are in mm [in.].

Fig. 1 — Dimensions of Tube Assemblies Provided in Accessory Kit

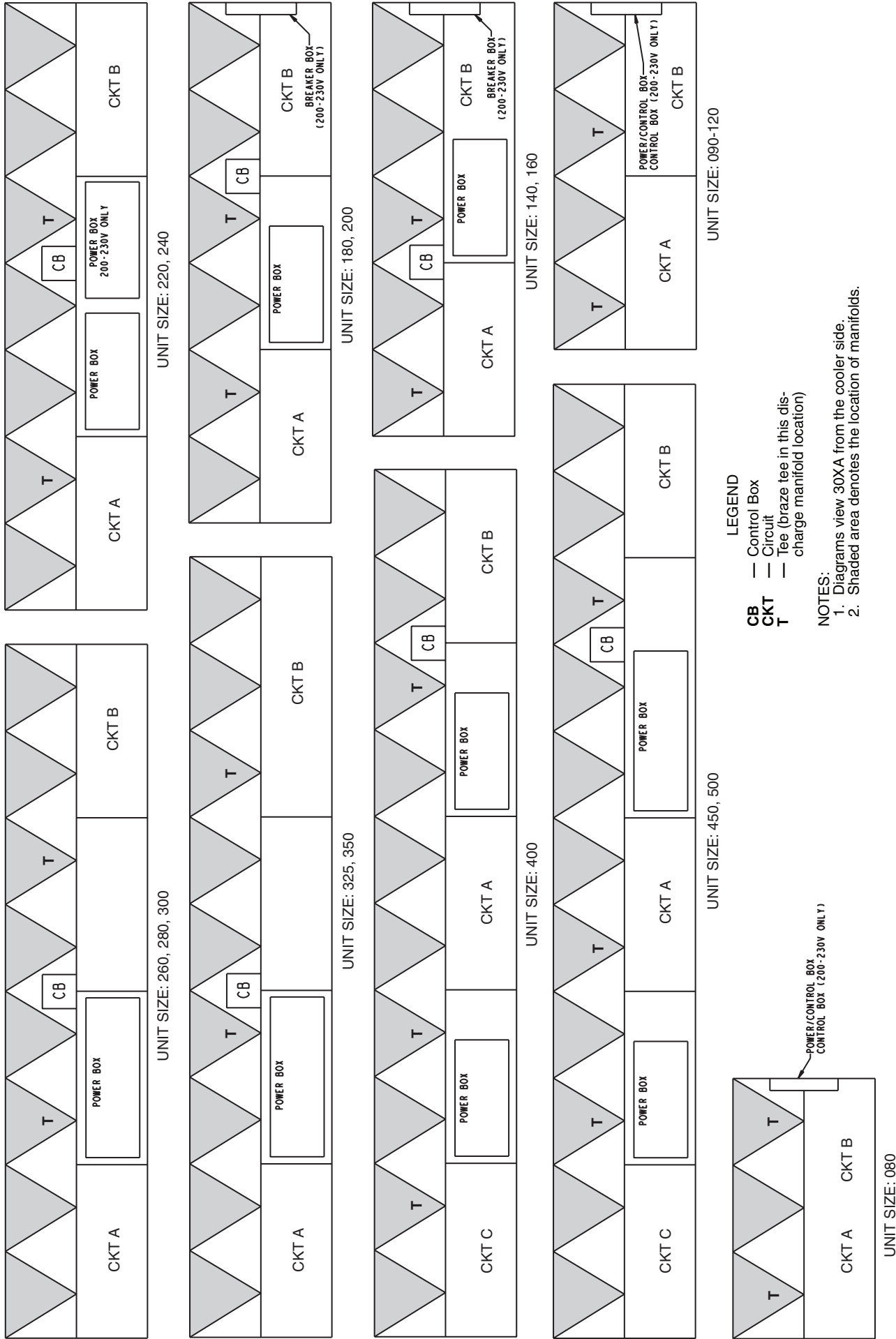

Fig. 2 — Discharge Manifold Location for Minimum Load Piping Per Circuit

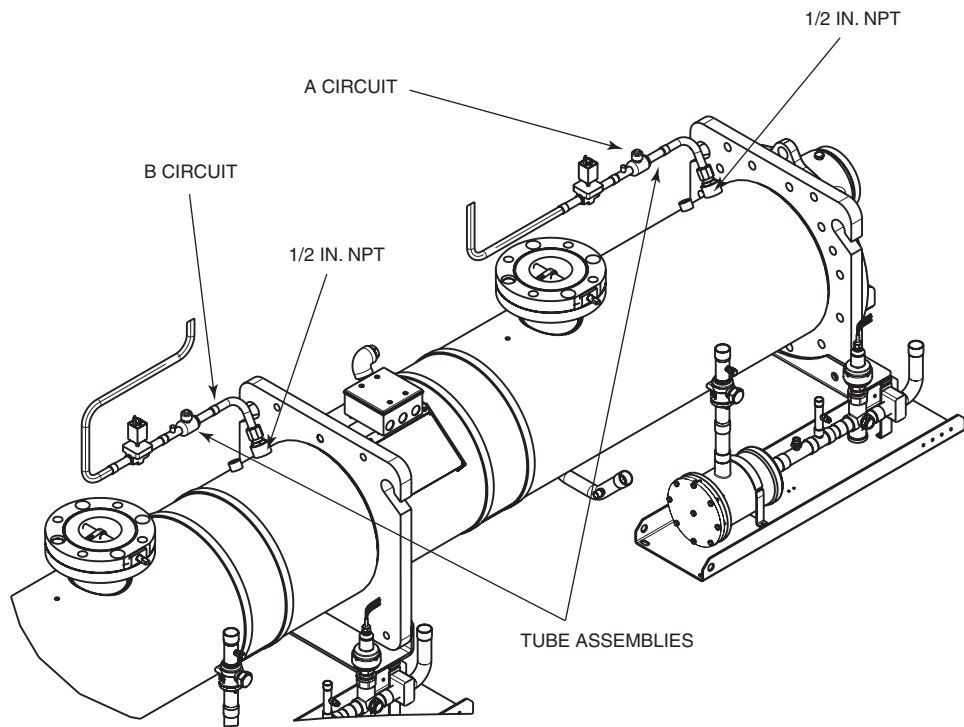

Fig. 3 — Typical Solenoid Valve Tube Assembly Installation

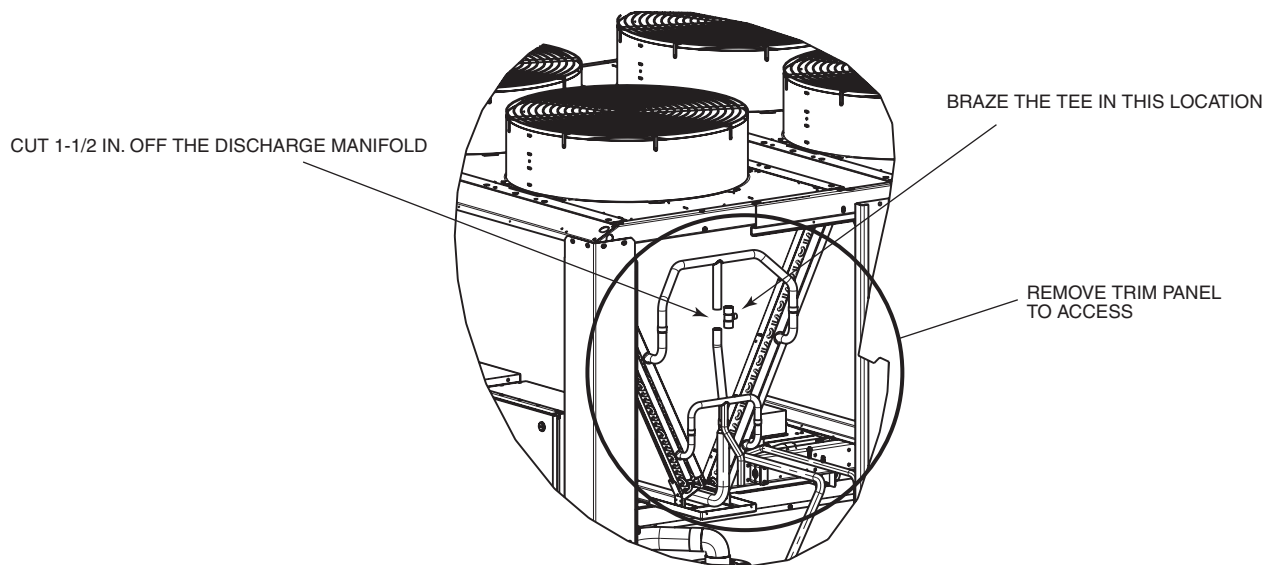

Fig. 4 — Discharge Manifold Modification and Tee Brazing

Install HGBP/Pump Board and Control Wiring

1. Attach the solenoid coil assembly to the solenoid valve plunger on the tube assembly for each circuit. One cable assembly TH70400410 is supplied per circuit. Secure the DIN connector end on the solenoid valve coil with the screw in the connector. Verify the square rubber gasket is in place to ensure connection remains watertight.

⚠ CAUTION

Take care connecting leads to terminal blocks. Incorrect polarity will damage the control boards.

2. Route the other end of the cable to the main control panel (where the display is located). For the circuit A solenoid, connect leads to TB5-7 and TB5-13. For the B circuit solenoid, connect leads to TB5-8 and TB5-13. For the C circuit solenoid (30XA400-500 only), connect the leads to TB5-6 and TB5-13. In all cases, the black wire from the solenoid must be connected to TB5-13 to ensure correct polarity.
3. Set the board address of the HGBP/Pump Board by positioning the dual in-line package (DIP) switches to the correct settings. See Fig. 5. Mount the HGBP/Pump board in the main control panel with the No. 8 screws provided (mounting standoff's required for 30XA080-120: 200 v, 230 v, 380 v and 30XA140-500: all voltages). See Fig. 6A and 6B for the board mounting location.
4. Mount the 24-v circuit breaker (CB14) in the CB14 mounting hole on the display bracket. See Fig. 6A and 6B for the mounting hole location.
5. Connect the 24-v power from TB10-X1 (30XA080-120: 460 v, 575 v only) or TB11-X1 (30XA080-120: 200/230 v and 30XA140-500: all voltages) to CB14 with the provided red wire in the harness assembly. Find two 2-pin plugs marked J1-11,12 with red and brown wires in the harness assembly. Connect the plug to the HGBP/Pump board J1 with the red wire connected to CB14 and the brown wire connected to TB10-X2 (30XA080-120: 460 v,

575 v only) or TB11-X2 (30XA080-120: 200/230 v and 30XA140-500: all voltages). See Fig. 7.

6. Using harness TH70400864 provided in the kit, connect TB5 pins 6 (30XA400-500 only), 7, 8, and 13 to HGBP/Pump board J2 CH3, CH4 and J3 CH5 (30XA400-500 only). Use the pins inside TB5. See Fig. 5.
7. For 30XA080-120: 200/230 v, 380 v and 30XA140-500: all voltages, disconnect the 3 pin plug on MBB J9B (or EMM board J9A) for communication and plug it in to the HGBP/Pump board J9. Use the additional communication cable assembly TH70400852 provided in the kit to connect between HGBP/Pump board J9 and MBB J9B (or EMM board J9A when EMM board exists). The communication cable in the TH70400864 harness will not be used. For 30XA080-120: 460 v, 575 v, connect the 3 pin plug of the communication cable in the TH70400864 harness to the HGBP/Pump board J9 and splice the other end of the cable to the communication network using the wire nuts provided in the kit. Be sure to splice the wires with same color together to ensure correct polarity.

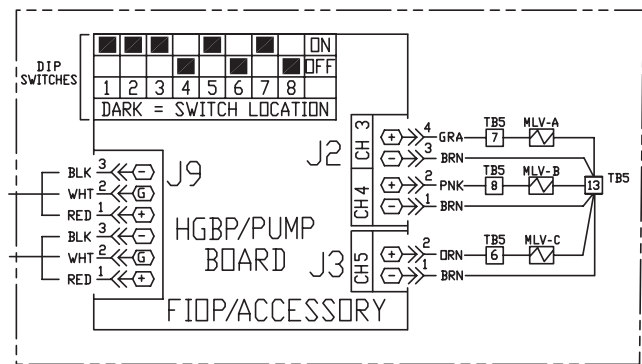

Fig. 5 — HGBP/Pump Board Address Switch and Wiring for Minimum Load Solenoid Output

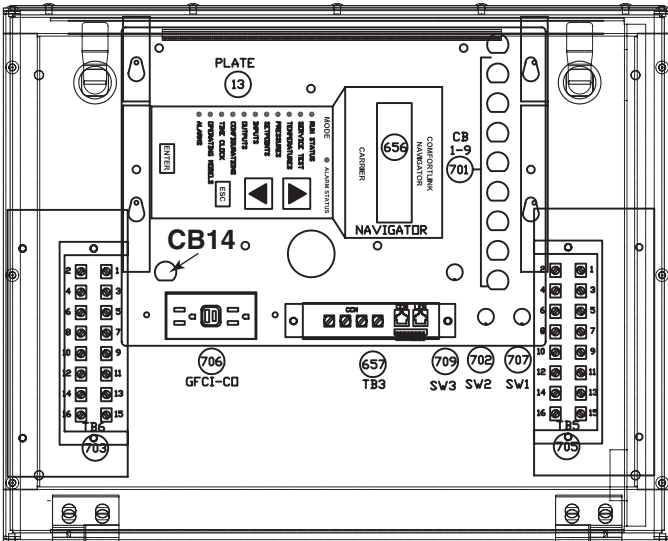
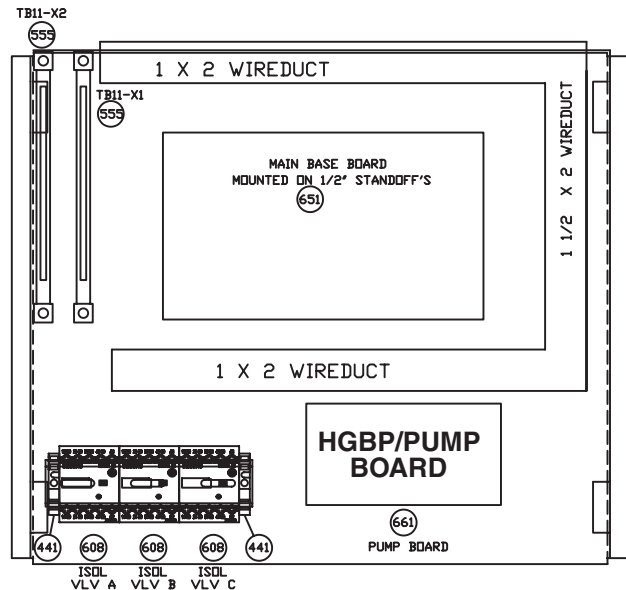

Fig. 6A — HGBP/Pump Board and CB14 Mounting Location (30XA080-120: 200 v, 230 v, 380 v and 30XA140-500: all voltages)



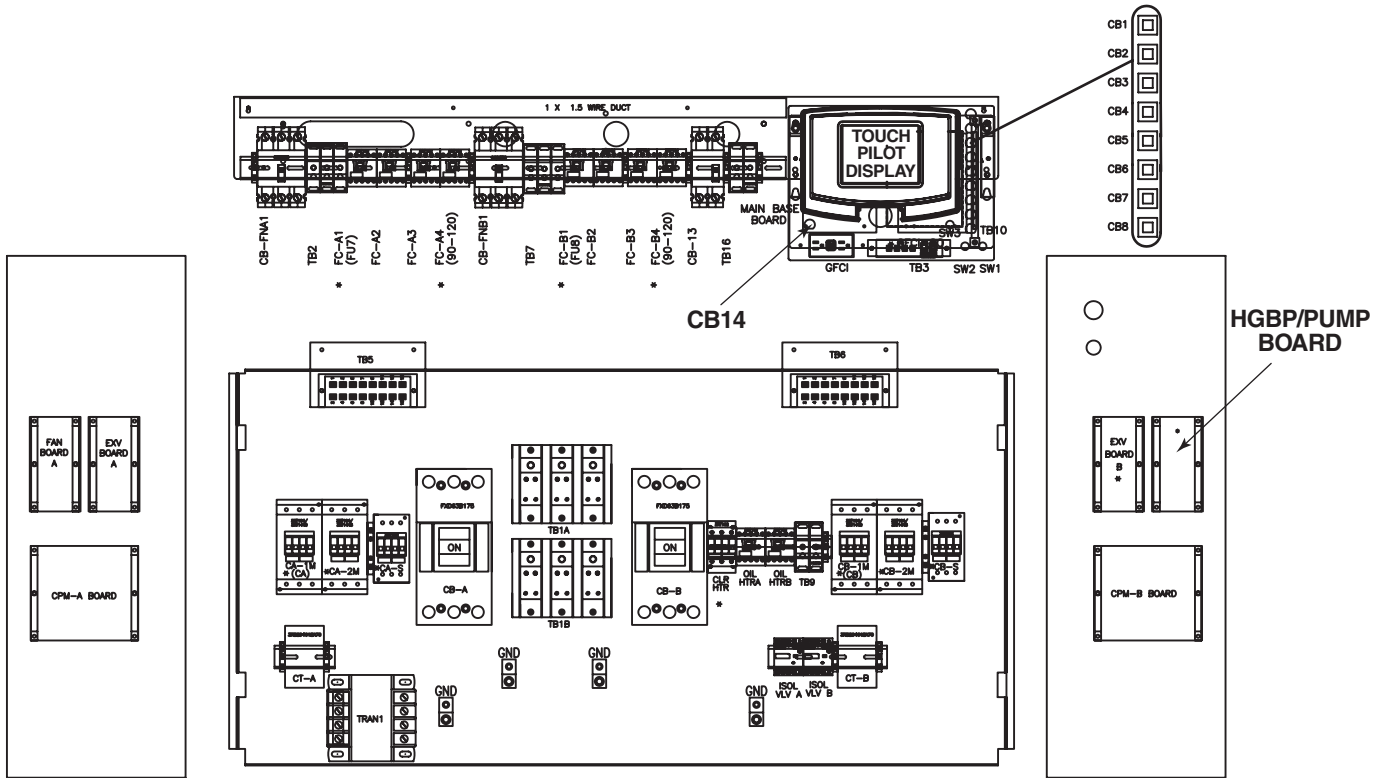

Fig. 6B — HGBP/Pump Board and CB14 Mounting Location (30XA080-120: 460 v, 575 v)

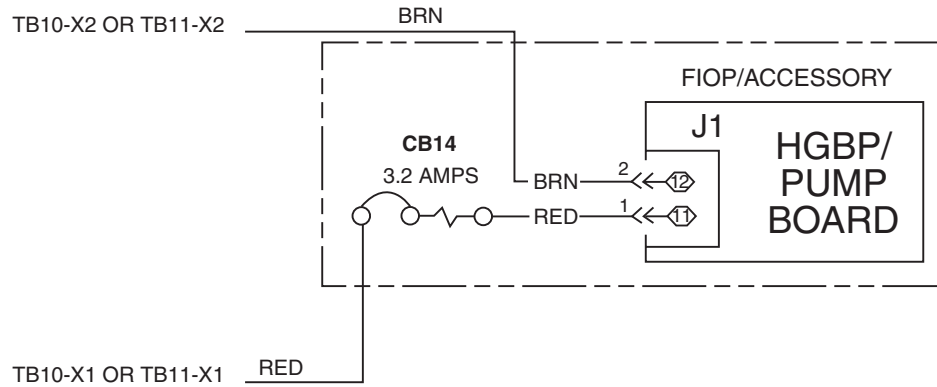











Fig. 7 — HGBP/Pump Board 24 v Power Wiring

Configure Unit for Minimum Load Control —

The controls must be configured for the minimum load control operation. Use the Touch Pilot™ or the Navigator™ display to configure the system. Refer to the 30XA Controls, Start-Up, Operation, Service, and Troubleshooting manual for additional information.

Complete the following steps to configure minimum load control with the **Touch Pilot** display:

1. Ensure the unit is in Local Off operating mode by looking at the upper left hand corner of the group display. If the unit is not in Local Off mode, press the Start/Stop button  to switch to the Local Off operating mode.
2. Press the main menu button  on the bottom line of the display, and then select Service→ Factory to navigate to the factory table.
3. Scroll down the screen by pressing the Scroll Down button  or the Page Down button  until Hot Gas Bypass Select is displayed on the screen. Press Hot Gas Bypass Select to display the Point Data dialog.
4. Press the Modify button . If the login menu is displayed, log in with the password. The default password is 3333. Press the OK button  to confirm the input. The value of hgbp_sel will display. Select Yes and press the OK button  to confirm the input.
5. Press the Home button  on the bottom line of the display. A save confirmation menu will display. Press the OK button  to confirm the action.
6. Wait 10 seconds and cycle the control power using the Emergency On/Off switch (SW2).

The chiller is now configured for minimum load valve control.













Complete the following steps to configure minimum load control with the **Navigator** display:

1. Set the Enable/Off/Remote switch to the Off position.
2. Press **[ESCAPE]** until the screen is blank and use the arrow key to select the Configuration mode LED.
3. Press **[ENTER]**, then use the arrow key to select the sub-mode 'UNIT', then press the **[ENTER]** key.
4. Press the down arrow key until 'HGBP' is displayed.
5. Press the **[ENTER]** key. If the login menu is displayed, log in with the password. The default password is 0 1 1 1. Use the arrow keys to change each number's value. Press the **[ENTER]** key after each number until finished.
6. Press the **[ENTER]** key so that 'No' flashes.
7. Use the arrow keys to change the value to 'Yes.'
8. Press the **[ENTER]** key.
9. Press the **[ESCAPE]** key until 'DISP' is displayed. Wait 10 seconds and cycle the control power using the Emergency On/Off switch (SW2).

The chiller is now configured for minimum load valve control.

Test Minimum Load Relay Output — Use the Touch Pilot or Navigator display's service test mode and the instructions given in their Controls, Start-Up, Operation, Service, and Troubleshooting manuals to verify proper operation of the solenoid(s).

For the **Touch Pilot** display:

1. Ensure the unit is in Local Off operating mode by looking at the upper left hand corner of the group display. If the unit is not in the Local Off mode, press the Start/Stop button  to switch to the Local Off operating mode.
2. Press the Main Menu button  on the bottom line of the display and then select Status→ Quick Test Enable.
3. Press the Force button . If the login menu is displayed, log in with the password. The default password is 3333. Press the OK button  to confirm the input.
4. The value of qck_test1 will display. Select On and press the OK button  to confirm the input.
5. Scroll down the screen by pressing the scroll down button  or the page down  button until Cir. A Hot Gas Bypass is displayed on the screen. Press Cir. A Hot Gas Bypass Select to display the Point Data dialog.
6. Press the Force button . Select On and press the OK button  to confirm input.
7. Verify that the Cir. A minimum load valve (MLV) solenoid is energized.
8. Proceed to Cir. B Hot Gas Bypass and Cir. C Hot Gas Bypass (30XA400-500 only) by pressing the page down button . Repeat Steps 5-7 for Cir. B MLV and Cir. C MLV.
9. Use the page up button  to return to the top of the table and select Quick Test Enable.
10. Press the Force button .
11. Select Off and press the OK button  to disable Quick Test.
12. Once the outputs have been tested, the installation is complete. Return the Touch Pilot to Local Off operating mode.

For the **Navigator** display:

1. Set the Enable/Off/Remote switch to the Off position.
2. Press **[ESCAPE]** until the screen is blank and use the arrow key to select the Service Test mode LED.
3. Press **[ENTER]**, then use the arrow key to select the sub-mode 'QUIC', then press the **[ENTER]** key.
4. Press the down arrow key until 'HGP.A' is displayed.
5. Press the **[ENTER]** key. If the login menu is displayed, log in with the password. The default password is 0 1 1 1. Use the arrow keys to change each number's value. Press the **[ENTER]** key after each number until finished.
6. Press the **[ENTER]** key so that 'Off' flashes.
7. Use the arrow keys to change the value to 'On.'
8. Press the **[ENTER]** key.
9. Verify that the Cir. A minimum load valve (MLV) solenoid is energized.
10. Proceed to 'HGP.B' and 'HGP.C' (30XA400-500 only) and repeat Steps 4-9 for Cir. B MLV and Cir. C. MLV.
11. Once the outputs have been tested, the installation is complete. Return the Enable/Off/Remote contact switch to the desired position.